



activTek[™] INDUCT 500

SECURE AIR PURIFICATION SYSTEM

PRINCIPLES OF OPERATION

The activTek INDUCT 500 utilizes tested ActivePure® Technology to substantially reduce odors, visible smoke in the air, and treat contamination on surfaces.

The activTek INDUCT 500 designed to be installed inside the ductwork of an in-wall heating and air conditioning unit. Optional ozone units are available with the same basic components as ozone-free units and an ozone bulb.

INSPECTION

1. Remove unit from shipping carton.
2. Remove all protective materials.
3. Check for loose or broken parts due to shipping damage.
4. Read owner's manual thoroughly prior to installation.
5. Determine placement location for the unit, follow installation instructions in this owner's manual.

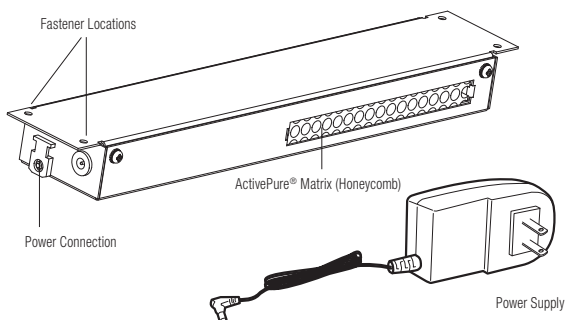

SPECIFICATIONS

Ozone Production:

- 0.00 ppm with ozone-free replaceable UV bulb.
- 0.40 ppm maximum with ozone replaceable UV bulb.

Features:

- ActivePure® Technology
- Convenient power cord

Electrical:

- AC Adapter

- Input: 100 -240VAC, 50/60 Hz, 1.2A
- Output: 12VDC, 3A

- activTek INDUCT 500

- 12VDC, 1.2A

Size:

- Height: 1.25" (3.175 cm); Width: 2.25" (5.72 cm); Length: 12.38" (31.45 cm)
- Weight: .7 lb (.3 kg), Unit only

Coverage:

- Up to 500 sq. ft. (46.5 sq. m)

Hg - LAMP CONTAINS MERCURY.
Manage in accordance with local laws.

Please record the name and phone of your independent activTek Environmental Distributor:

Name _____

Phone _____

Please record the serial number of your activTek INDUCT 500:

Serial # _____



WARNING! - UV Lamp operation. Do not operate unless the unit is completely and correctly assembled. Failure to comply may result in serious eye damage.



CAUTION! - For outlet installation only! Never connect to an extension cord or other power source. Improper installation could result in electrical shock or short.

CAUTION: READ AND SAVE THESE INSTRUCTIONS FOR PROPER PROCEDURES AND OPERATION.

INSTALLING THE UNIT



WARNING: Disconnect power to the AC unit at the breaker or fuse panel before installing unit.



WARNING: It is recommended that this unit be installed by a licensed HVAC contractor to ensure proper installation and protect your warranty.

1. Installation will require removal of the PTAC air unit cover. Please refer to your PTAC unit's owner's manual for detailed instructions.

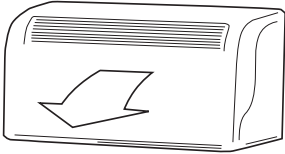

2. Placement of the INDUCT 500 varies depending on your PTAC unit design. However, the INDUCT 500 should be placed directly in the unit's airflow (see **NOTE** on this page).

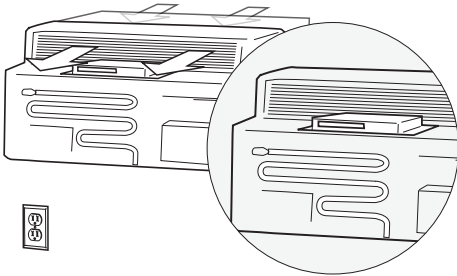

3. Connect the Induct 500's power supply cord by inserting the plug into power inlet (a). Spin the retainer clip (b) up and place power supply cord under retainer. Return retainer clip to its original position.

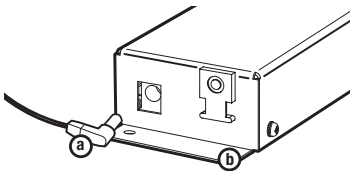

NOTE: ACTIVTEK INDUCT 500 PLACEMENT

Air Flow:

The INDUCT 500 should be placed in the direct air flow of your PTAC unit. Optimum placement will allow air to pass into the INDUCT 500 from one side and exit on the opposite side. (See diagram.)

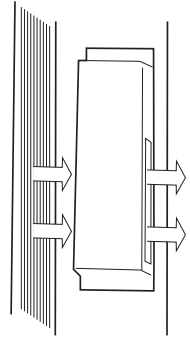

Downward View

4. Place the power cord in an out-of-the-way location toward the electrical outlet.

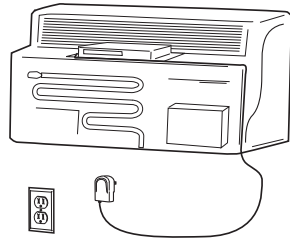

5. Replace the cover on the PTAC air unit and plug in the INDUCT 500's power cord into the electrical outlet.

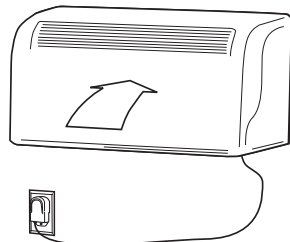

CHANGING THE UV BULB

NOTE: We recommend changing the UV bulb in the INDUCT 500 once a year, if cycled with fan on/off, and every 2 years, for continuous operation. If the INDUCT 500 unit is connected to the fan circuit, it will only operate when the fan runs. The INDUCT 500 unit can operate continuously if it is connected separately from the fan.



WARNING: Disconnect Power from the INDUCT 500 before servicing.



WARNING: UV Light in operation. Disconnect unit from power supply before servicing. Failure to follow warnings may result in severe eye damage and electrical shock.

1. Remove the four (4) cover screws from the sides of the INDUCT 500.

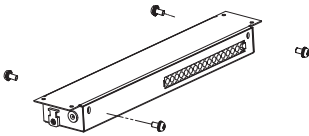

2. Remove the cover by lifting away from the base.

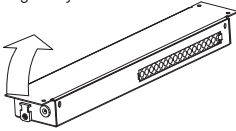

3. Remove the UV bulb by lifting the end away from the bulb retaining clamp.

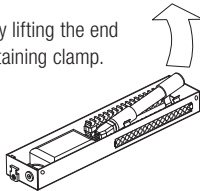

4. Unplug the UV bulb from the power supply.

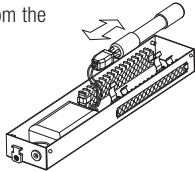

5. Replace the UV bulb by reversing steps 3 and 4.

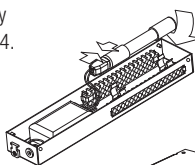

6. Return cover and replace screws.

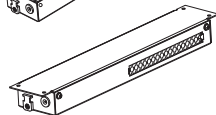

PARTS VIEW

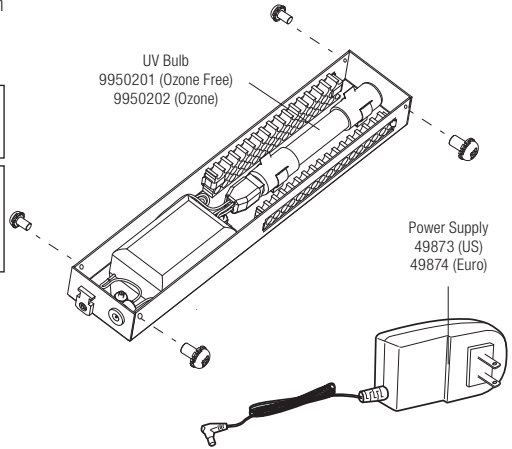

CLEANING/MAINTENANCE

NOTE: It is recommended to vacuum the ActivePure Matrix (honeycomb) surface monthly.

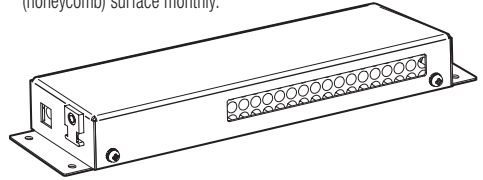

1. Disconnect the power supply to the INDUCT 500 and the PTAC unit.
2. Remove the INDUCT 500 from PTAC the unit.
3. Wipe the cover of the INDUCT 500 with a damp cloth.
4. Use a vacuum with a hose attachment to vacuum dust from the ActivePure Matrix (honeycomb) on either side of the INDUCT 500.
5. When the INDUCT 500 cover is free from moisture, reposition in the PTAC and plug power supply back into outlet.

FCC DECLARATION OF CONFORMITY

Name: activTek Environmental

Model: activTek INDUCT 500

This device complies with Part 18 of the FCC Rules.

RESPONSIBLE PARTY



DBG Group Investments, LLC
300 East Valley Drive
Bristol, VA 24201

Ph: 866.736.0503

Signature:

Printed Name: Andy Eide

Title: Vice President, Product Development & Research

Date: 01/04/17

This equipment has been tested and found to comply with the limits for Industrial, Scientific, and Medical Equipment (ISM), pursuant to Part 18 of the FCC Rules. These limits are designed to provide reasonable protection against harmful interference in a residential installation. This equipment generates, uses, and can radiate radio frequency energy, and if not installed and used in accordance with the instructions, may cause harmful interference to radio communications. However, there is no guarantee that interference will not occur in a particular installation. If this equipment does cause harmful interference to radio or television, which can

be determined by turning the equipment off and on, the user is encouraged to try to correct the interference by one or more of the following measures:

Reorient or relocate the receiving antenna.

Increase the separation between the equipment and receiver.

Connect the equipment into an outlet on a circuit different from that to which the receiver is connected.

Consult the Distributor or an experienced radio/TV technician for help.

Did you forget to register your activTek INDUCT 500 with activTek Environmental?

By registering, you'll activate your warranty.

Just fill out your warranty card and drop it in the mail.

WARRANTY INFORMATION

LIMITED 3 YEAR WARRANTY

Customer should not repackaging and ship the INDUCT 500 unit due to possibility of irreparable damage. For warranty service, please contact your activTek Distributor for the address of the nearest service center or call Customer Service at 866.736.0503.

WHAT IS COVERED BY THIS WARRANTY

We warrant the INDUCT 500 (excluding filters) to the Customer, subject to the conditions below, against defects in workmanship or material, provided that the products are returned to a service location within the following time periods:

- INDUCT 500 within three (3) years of date of purchase.
- ActivePure Bulb within one (1) year from the date of purchase.

INSTALLATION AND MAINTENANCE REQUIREMENTS

This warranty is expressly conditioned upon proper installation, operation, cleaning and maintenance, all in accordance with the Owner's Manual. Failure to meet any of these requirements will void this warranty. Servicing of your INDUCT 500 by parties other than our authorized representatives and/or using parts other than genuine parts will also void this warranty.

HOW TO OBTAIN WARRANTY SERVICE

Customer must contact their activTek Distributor and provide proof of purchase within the above time periods. We will repair or replace and return the product, without charge and within a reasonable period of time, subject to the conditions herein, if its examination shall disclose any part to be defective in workmanship or material. If we, in our discretion, are unable to repair the product after a reasonable number of attempts,

we will provide either a refund of the purchase price or a replacement unit, at the company's option.

WHAT IS NOT COVERED BY THIS WARRANTY

Ordinary wear and tear shall not be considered a defect in workmanship or material. These warranties do not apply to filters nor for loss or damage caused by accident, fire, abuse, misuse, improper installation, leaking, modification, misapplication, or by any repairs other than those provided by our authorized Service Center. This warranty is non-transferable.

MISSING SERIAL NUMBERS AND UNAUTHORIZED CHANNELS

If a valid serial number is missing from the product, the warranty will be voided. ActivTek products are authorized for sale through activTek Distributors only. Warranties are voided if a product is purchased through unauthorized channels; this includes websites that are not authorized to use activTek's trademarked names, images and logos as well as Internet auction sites (e.g. eBay and craigslist). The only approved Internet presence for activTek products is www.activTek.net. To confirm warranty coverage prior to purchasing a product, contact activTek at 866-736-0503 with the serial number located on the back of the unit.

EXCLUSION OF OTHER WARRANTIES AND CONDITIONS EXCEPT AS PROVIDED HEREIN, WE MAKE NO REPRESENTATION OR WARRANTY

OF ANY KIND. ALL OTHER WARRANTIES OF ANY KIND, EXPRESS OR IMPLIED, ARE HEREBY EXPRESSLY DISCLAIMED, INCLUDING ANY IMPLIED WARRANTY OF MERCHANTABILITY OR FITNESS FOR A PARTICULAR PURPOSE.

LIMITATION OF LIABILITY FOR SPECIAL, INCIDENTAL, OR CONSEQUENTIAL DAMAGES
WE SHALL NOT IN ANY CASE BE LIABLE FOR SPECIAL, INCIDENTAL OR CONSEQUENTIAL DAMAGES ARISING FROM BREACH OF EXPRESSED OR IMPLIED WARRANTIES, CONDITIONS, GUARANTEES OR REPRESENTATIONS, BREACH OF CONTRACT, NEGLIGENCE OR ANY OTHER LEGAL THEORY. Such excluded damages include, but are not limited to, loss of profits or revenue, and loss of the use of the products, and any loss caused by leaks or other water damage.

FOR U.S. APPLICATION ONLY

This warranty gives you specific legal rights, and you may also have other rights which vary from state to state. Some states do not allow limitations on warranties, or on remedies for breach. In such states, the above limitations may not apply to you.

FOR CANADIAN APPLICATION ONLY

Exclusion of Subsequent Owners: Except as otherwise required by applicable legislation, this warranty is not transferable. This warranty gives you specific legal rights and

you may also have other rights which vary from province to province.

Some provinces and territories do not allow limitations on warranties, or on remedies for breach. In such provinces or territories, the above limitations may not apply to you. If any provision of this warranty or part thereof is held by a court of competent jurisdiction to be invalid, illegal, or unenforceable, the validity, legality and enforceability of the remaining provisions or parts thereof will not in any way be affected or impaired within the jurisdiction of that court. This entire warranty shall continue to be valid, legal and enforceable in any jurisdiction where a similar determination has not been made.

This warranty is provided by DBG Group Investments, LLC
300 East Valley Drive
Bristol, VA 24201.

SERVICE

Every effort is made to ensure customers receive an up-to-date instructions manual on the use of our products; however, from time to time, modifications to our products may without notice make the information contained herein subject to alteration. For the latest information, please visit our web site.



DBG Group Investments, LLC
dba activTek Environmental
300 East Valley Drive
Bristol, VA 24201